

4

3

2

1

D

D

C

C

B

B

A

A

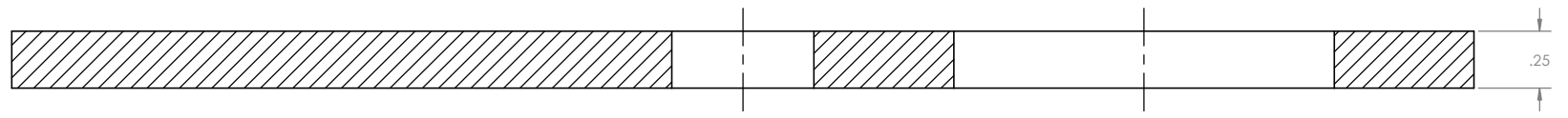
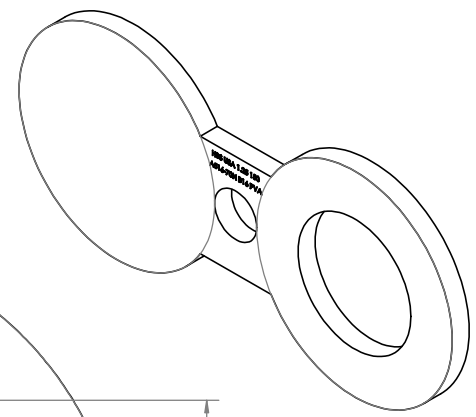
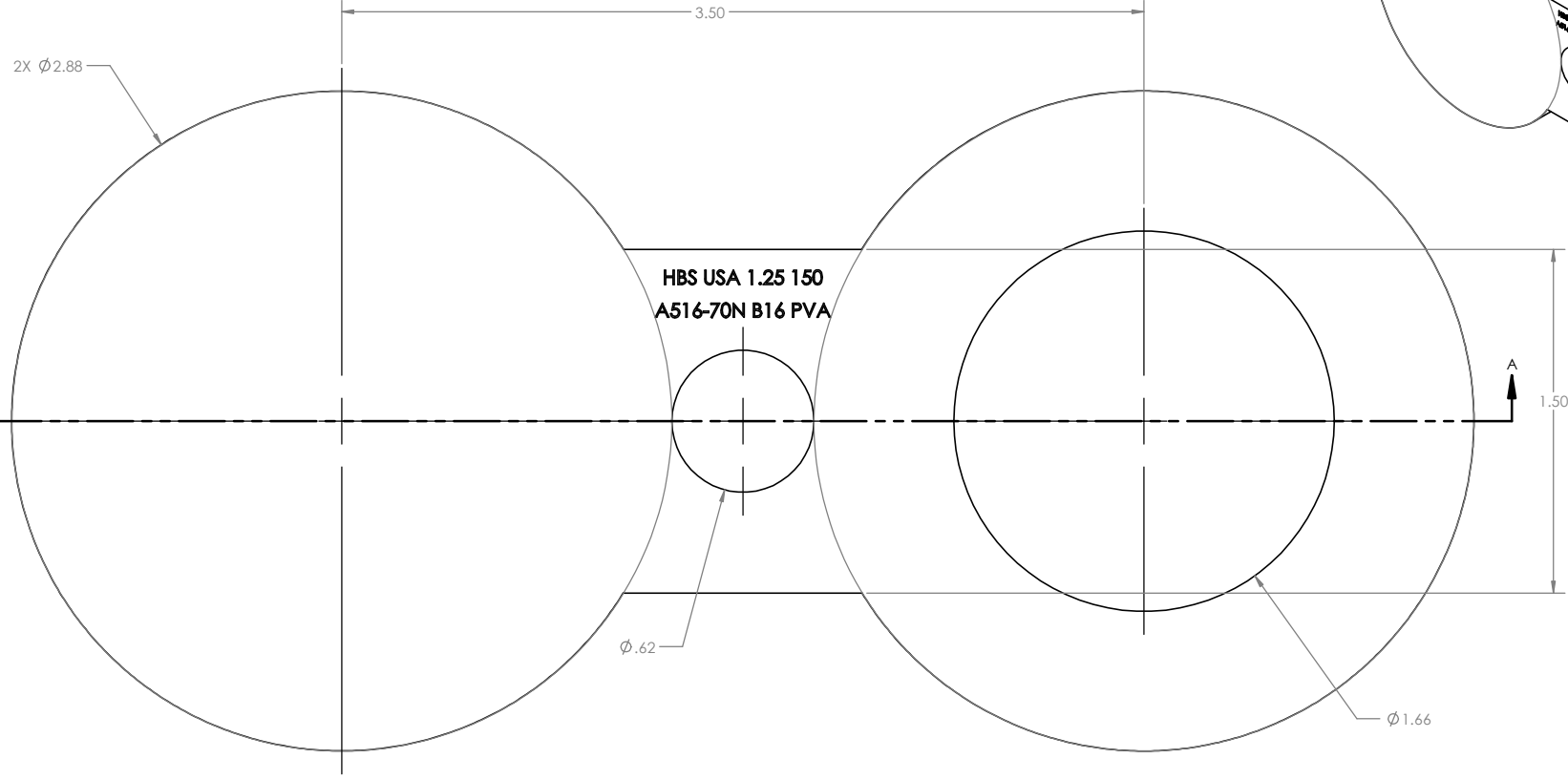

SECTION A-A

DO NOT SCALE PRINT		UNLESS OTHERWISE SPECIFIED: OUTSIDE DIAMETER: (+/-0.12) INSIDE DIAMETER: (+/-0.12) THICKNESS TOLERANCES (-ZERO +0.12) ALL UNITS IN INCHES OR POUNDS		HYDROBLIND -ISOLUTIONS	
		SHEET 1 OF 1			SURFACE FINISH: MACHINE OR MILL
MATERIAL: CUSTOMER REQUESTED		DATE: 06/24/2020		DRAWING TITLE: 1-1/4 CL 150 FIGURE 8 BLIND	
SCALE 1:0.4		DIMENSIONS & TOLERANCES TO BE IN ACCORDANCE WITH ASME B16.48			WEIGHT 1 lb
SIZE C		DRAWING NUMBER: 1SBI			REV 00

4

3

2

1